

Bottom view / Вид снизу

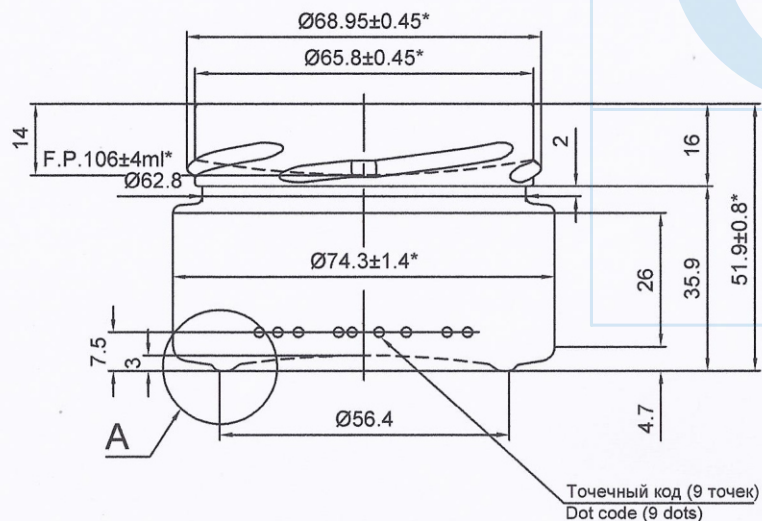
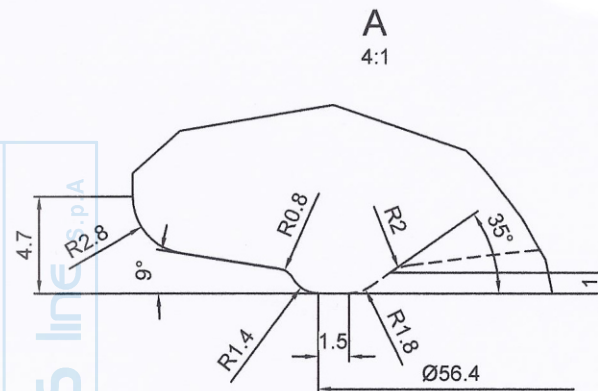
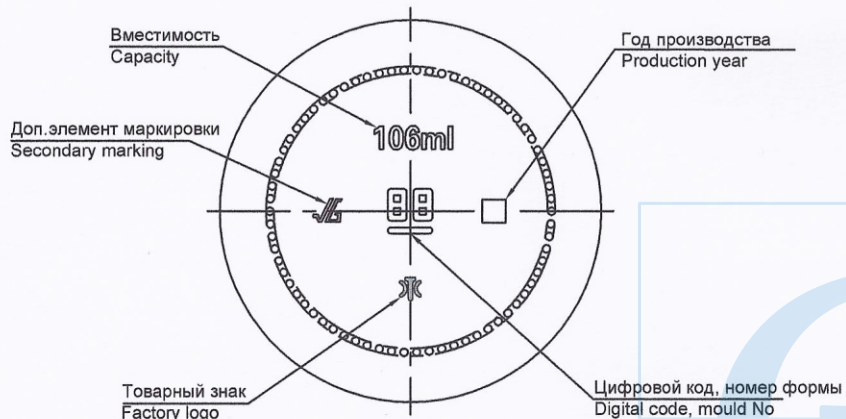

- *Контролируемые размеры. Остальные размеры для изготовления формокомплекта. (Controlling dimensions. Other dimensions for the manufacture of mold sets.)
- Полная вместимость, см³ (Full capacity, ml) - 145±4;
- Номинальная вместимость, см³ (Nominal capacity, ml) - 106±4;
- Масса рекомендуемая, г (Weight recommended, g) - 130;
- Тип венчика (Finish type) -III-4-70(TO-70 DEEP);
- Толщина минимальная (Minimum Thickness):
 - стенка, мм (Wall, mm) -1,2;
 - дна, мм (Bottom, mm) -2,0.

7. Технические требования по ГОСТ 5717-91 и по ТУ У 26.1-04763746-027:2009. (Technical requirements according to ГОСТ 5717-91 and ТУ У 26.1-04763746-027:2009)

NAME	DATE	REVISIONS	MOLD No:		A3	CENTERGLASSLINE SPA	
V.Y.	08.12.17	Added logo on the bottom	FINISH No:				
V.Y.	02.02.18	Changed body dimens., brimf.capacity, F.P.	PROCESS	PB	MACHINE	DG 5 1/2"	JAR:
			TYPE	OW	TIP ANGLE	-	ELENA 106ML
			CAP. BRIMF.	145±4ml	REF MOLD:	-	CAT.No & DWG No:
			CAP. FILLPT.	106±4ml	FINISH:	III-4-70(TO-70 DEEP)	3.89-III-4-70-106
			FILL LINE	14mm	DRAWN	Yatseniuk	
			WEIGHT	130g	CHECKED	Dovgopol	DATE 16/11/17
			COLOR	FLINT	CONFIRMED	Solomon	SHEET: 1/1 SCALE: 1:1